



**EnerRocket™**  
CONTINUOUSLY SAFEGUARDING

# ES 42-12

SMF VRLA RECHARGEABLE BATTERY

**LONG  
LIFE  
SERIES**

## APPLICATIONS

- UPS Systems
- Telecommunication Systems
- Fire Alarm Safety & Security Systems
- Medical Equipment

## COMPLIANCE STANDARDS

- IEC 60896 PART 21 & 22
- BS6290-4

## TECHNICAL FEATURES



- Non-Spillable Sealed Construction
- Seal Lead Acid Battery
- Absorbent Glass Mat System (AGM System)
- ABS (Acrylonitrile Butadiene Styrene) construction (FR optional)
- Gas Recombination
- Venting System for low internal pressure
- Low Self-Discharge
- Heavy-Duty, Highly Optimized Grids
- High Power Output
- Wide Operating Temperature
- Maintenance-Free Operation

## CHARACTERISTICS

Nominal Voltage	12 V	
Design Life	10 Years	
Capacity 25°C (77°F)	20 Hour rate	42Ah
	10 Hour rate	40Ah
	5 Hour rate	37.55Ah
Internal Resistance (25°C, 100% Charge)	≤ 9.0 mΩ	
Self Discharge (20°C)	1 Month	Remaining Capacity 97%
Operating Temperature	Discharge	-20°C - 60°C
	Charge	-10°C - 60°C
	Storage	-20°C - 60°C
Normal Operating Temperature	25°C ± 3°C	
Maximum Discharge current	400A (5sec)	
Maximum Charging current	16A	
Short Circuit Current	950A	
Charge Methods Constant Voltage Charge 77°F (25°C) - Cycle use	14.4 to 14.7V	
	Temp. Compensation -30mV/°C	
Charge methods Constant Voltage Charge 77°F (25°C) - Standby Use	13.4 to 13.8V	
	Temp. Compensation -20mV/°C	

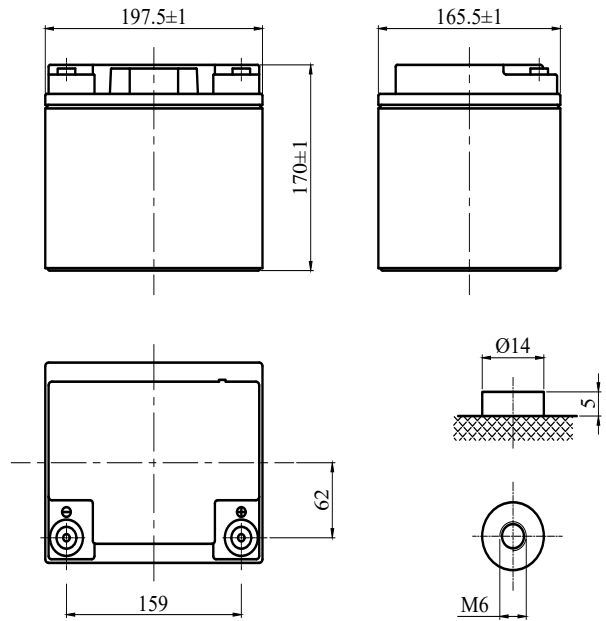

## SPECIFICATIONS

Length	Width	Height	Total Height	Weight (kg)
197 mm	165 mm	170mm	170 mm	12.8 ± 5%

### CONSTANT CURRENT DISCHARGE (Amperes) AT 25°C

End Voltage Volts/Cell	5min	10min	15min	30min	1h	3h	5h	10h	20h
1.60	130	90.5	72.7	41.9	25.9	11.3	7.95	4.20	2.25
1.65	122	86.2	69.1	40.6	25.4	11.1	7.81	4.15	2.22
1.70	114	81.8	66.5	39.2	24.8	10.9	7.67	4.10	2.18
1.75	106	77.6	63.0	37.7	24.2	10.6	7.51	4.05	2.14
1.80	97	73.9	59.2	36.2	23.5	10.4	7.35	4.00	2.10

### CONSTANT POWER DISCHARGE (Watts) AT 25°C

End Voltage Volts/Cell	5min	10min	15min	30min	1h	3h	5h	10h	20h
1.60	236	163	127	83.2	50.9	21.5	14.0	8.76	3.9
1.65	220	157	124	81.8	50.2	21.2	13.8	8.59	3.9
1.70	204	150	121	79.3	49.3	20.8	13.6	8.42	3.8
1.75	186	143	117	76.8	48.5	20.5	13.4	8.21	3.8
1.80	177	135	113	74.3	47.7	20.1	13.3	8.04	3.7



## ES 42-12

SMF VRLA RECHARGEABLE BATTERY

**LONG  
LIFE  
SERIES**

